

Camshelving® ELEMENTS series

STATIONARY | MOBILE | UNDERCOUNTER

Why Choose Elements?

- Easy to clean and adjust.
- Ideal for coolers, freezers and warewashing areas.
- Made from extremely strong composite and plastic materials.
- Impervious to harsh chemicals and salt water.



camguard
ANTIMICROBIAL SHELF PLATES



COMPONENT

Post Connectors, Corner Connectors, Seismic Foot, Wall Fastener, Identification Tags, Single Shelf Security Cage, Single Shelf Sheet Pan/Tray Rack, and Shelf Divider Bars are not NSF Listed.



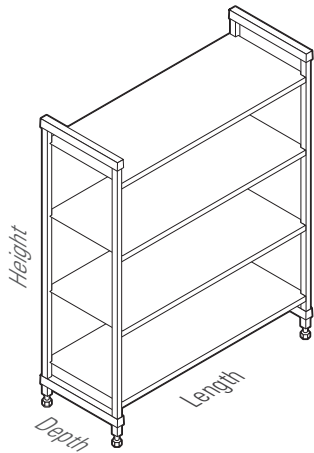

Stationary Unit Sizes

4 Depths
14" 18" 21" 24"
8 Lengths
24" 30" 36" 42" 48" 54" 60" 72"
3 Heights
64" 72" 84"

Mobile Unit Sizes

3 Depths
18" 21" 24"
5 Lengths
36" 42" 48" 54" 60"
2 Heights
70" 78"

Undercounter Unit Sizes

2 Depths
14" 18"
3 Lengths
24" 36" 48"
2 Heights
27" (Mobile) 30" (Stationary)

Weight Bearing Capacity

		UNIT LENGTH 24" – 48"	UNIT LENGTH 54" – 72"
SINGLE UNIT	Unit only	2000 lbs.	2000 lbs.
	Shelf only	800	600
	Unit with dunnage stand*	2400	2300
	Bottom shelf with dunnage stand*	1200	900
CORNER UNIT ** with 2 Dunnage Stands required	Unit only	1800	—
	Shelf only	400	—
	Bottom shelf with dunnage stands*	600	—
MOBILE UNIT	Unit only***	750	—

* Dunnage Stands add stability and increase weight bearing capacity on bottom shelf only. Add to any shelf length. Highly recommended for Starter Units 54" and longer, all Corner Units, U-Shape Units and units specified for heavier loads.

** Corner connectors are for use only with shelves 24" - 48" long.

*** Due to the weight bearing capacity of casters, maximum weight load on an entire Mobile Unit is 750 lbs.